

This reprint includes all changes in effect  
at the time of publication; change 1.

TM 9-1005-233-10

# OPERATOR'S MANUAL

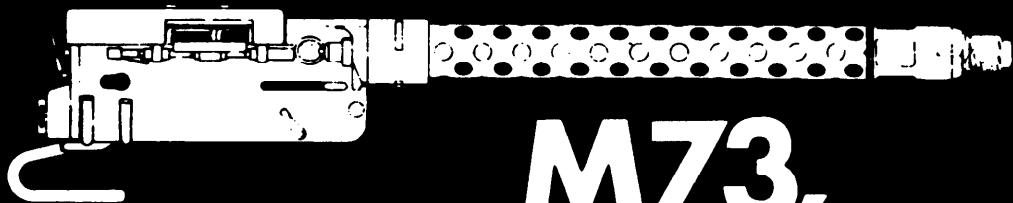

# M73,

1005 00 869 8816

# M73A1 AND M219

1005 00 937 7323

1005 00 077 2354

# MACHINE GUNS

JULY  
1974



# WARNING

- Keep the weapon aimed on target until the gun is cleared. Don't let anybody get in the way of the barrel.
- Clear the gun whenever you don't intend to fire. Then, eyeball the chamber to make sure it's empty.
- Let a hot weapon that stops firing cool at least 15 minutes before you open the cover (if you've fired 200 rounds in 2 minutes the hot chamber could cook off the next one, bad news with an open cover).
- Charge the weapon using the handle of the chain, never use your hands on the barrel extension.
- When your weapon is charged, always put the safety on "S".
- CAUTION: When you reassemble the weapon after cleaning make sure the barrel extension is in the forward position with the safety on "F".

TM 9-1005-233-10

C1

CHANGE

NO. 1

**HEADQUARTER  
DEPARTMENT OF THE ARMY  
Washington, D. C., 10 May 1977**

Operator's Manual

M73,

**1005-00-869-8816**

M73A1

and

M219

**1005-00-937-7323**

**1005-00-077-2354**

**MACHINE GUNS**

**TM 9-1005-233-10, July 1974, is changed as follows:  
The following pages replace pages 6, 7, 8 and 9.**

# BASIC ISSUE ITEMS

These items must accompany weapon during operation and whenever it is transferred between accountable officers. This manual is your authority to requisition replacement BLL.

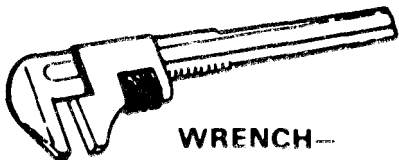

WRENCH—

5120-00-264-3793



COMBINATION TOOL—

4933-00-733-4759



PUNCH—

5120-00-242-5966



RUPTURED CARTRIDGE  
CASE EXTRACTOR—

4933-00-652-9950

TM9-1005-233-10

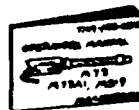

# BASIC ISSUE ITEMS continued

**SMALL ARMS CLEANING ROD CASE—**

**1005-00-550-6573**

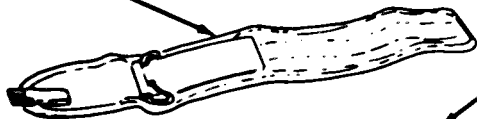

**CLEANING ROD  
SECTION (5)—**

**1005-00-726-6109**

**HANDLE—**  
**1005-00-793-6761**



**BUFFER—**  
**1005-00-694-1662**

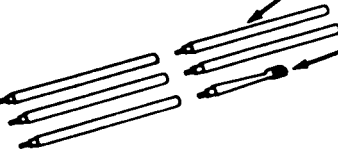

**SWAB HOLDER  
SECTION—**

**1005-00-726-6110**

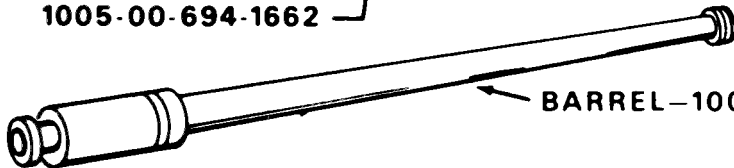

**BARREL—1005-00-972-0196**

# ADDITIONAL AUTHORIZED LIST

These items do not have to accompany the weapon and do not have to be turned in with it.



**CHAMBER BRUSH—1005-00-690-3115**



**BORE BRUSH—1005-00-556-4174**

# EXPENDABLE SUPPLIES and MATERIALS LIST

This page lists expendable supplies and materials you will need to operate and maintain the weapon. These items are authorized to you by, CTA 50-970, Expendable Items (Except Medical, Class V, Repair Parts and Heraldic hems).

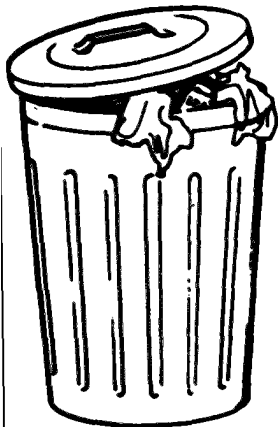

SWABS-1005-00-288-3565 - 1 pkg.

LSA-9150-00-889-3522-4 oz.

**ANY CHANGES, COMMENTS, or IDEAS**

**Write to us ON DA FORM 2028**

**(or whatever you have handy)**

**We have a new address**

COMMANDER  
U.S. ARMY ARMAMENT MATERIEL READINESS COMMAND  
ATTN: DRSAR-MAS  
ROCK ISLAND, ILLINOIS 61201





**By Order of the Secretary of the Army:**

**BERNARD W. ROGERS**  
**General, United States Army**  
**Chief of Staff**

**Official:**

**PAUL T. SMITH**  
**Major General, United States Army**  
**The Adjutant General**

**Distribution:**

**To be distributed in accordance with DA Form 12-40,  
Operator's maintenance requirements for Gun, Machine,  
7.62-MM M73 (Tank).**

# WHAT IS THE M73, M73A1, M219?

.... It's a 7.62 mm. tank machine gun.

	M 7 3	M 7 3 A 1 / M 2 1 9
WEIGHT	31 Lbs	29.80 Lbs
LENGTH	35 in.	<b>OTHERWISE, ALL THE SAME</b>
FEED	Right or Left	
RATE OF FIRE (cyclic)	500-625 Rds per min.	
Max. Eff. Range	900 Meters (Tracer burn-out)	

# About your Machine gun. . . .

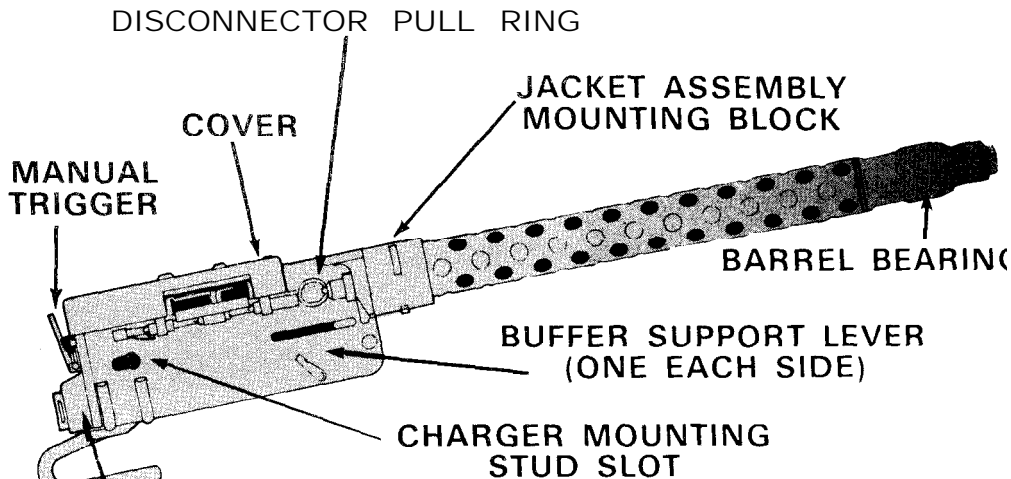

**CAUTION:** Do not stand gun on end — damage to the back plate trigger could result.

# "Where to find it." . . . .

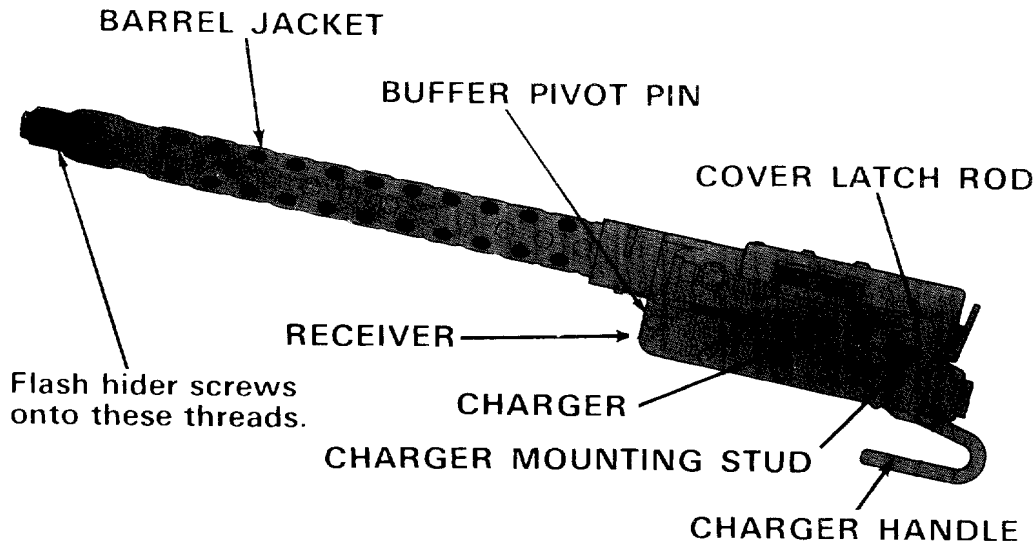

# WHAT'S THE DIFFERENCE??

**INSIDE** the guns it's mostly the barrel extension assembly and the feed tray . . . **DON'T SWITCH THEM AROUND** from one model to another, the gun won't work.

CARRIER ASSEMBLY

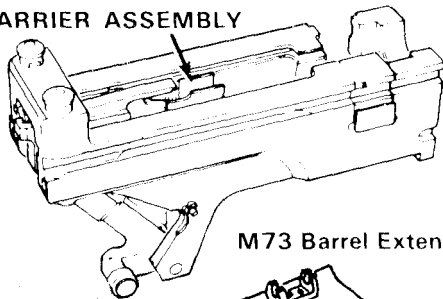

M73 Barrel Extension

M73 Feed Tray  
(underside)

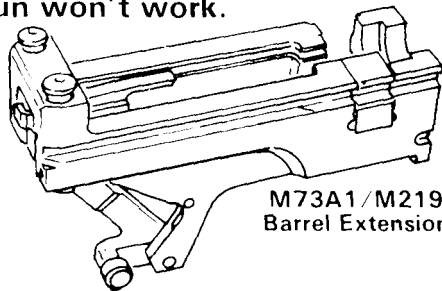
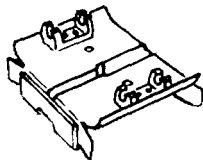

M73A1/M219  
Barrel Extension

FIXED  
EJECTOR

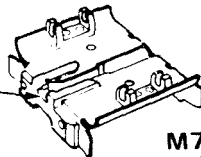

M73A1/M219  
Feed Tray  
(underside)

Use cartridge stop assembly p/n 8448780,  
1005-00-003-1073 on M73, M73A1 and M219

# HERE'S THE DIFFERENCE!!

OUTSIDE the Receiver . . .

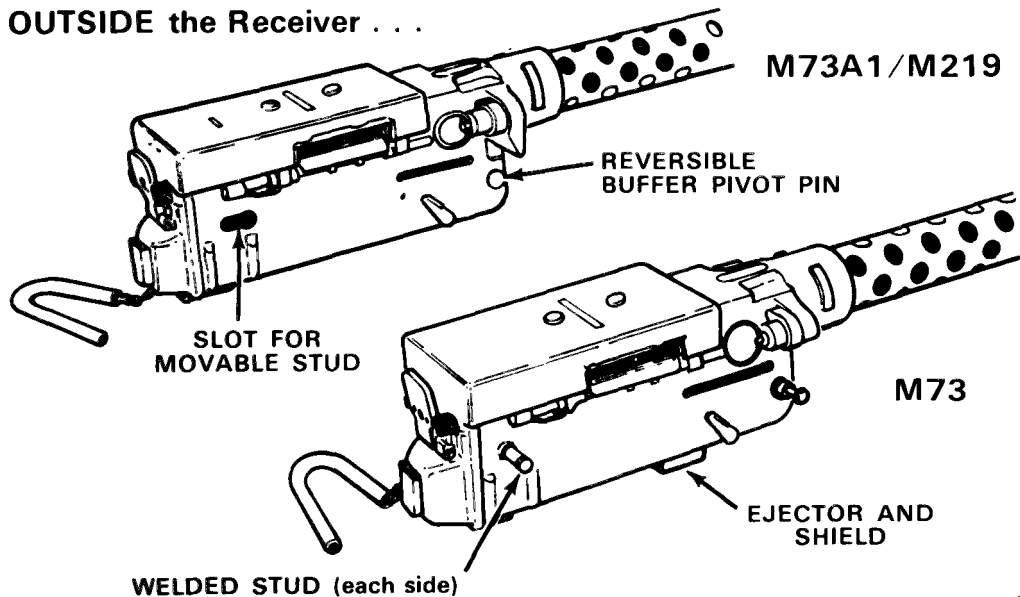

# ITEMS

## TROOP INSTALLED OR AUTHORIZED

These items, at the discretion of your CO, may accompany your machine gun, but are not required to be turned-in with the machine gun.

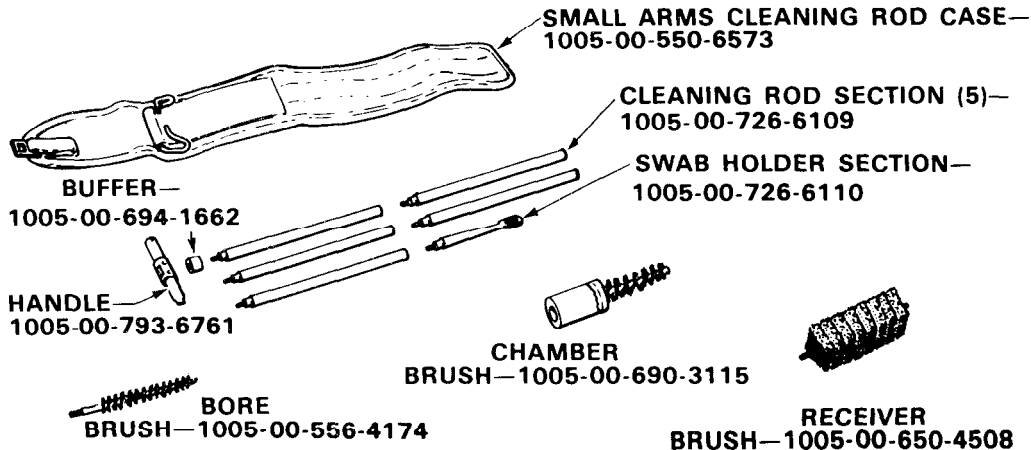



## CONSUMABLE & EXPENDABLE ITEMS

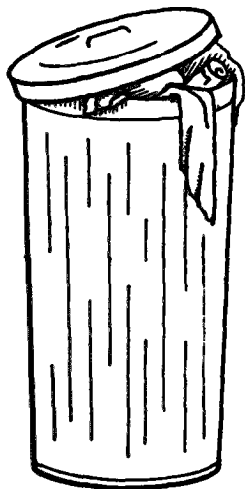

<b>PL Special</b>	<b>- 4 oz.</b>	<b>- 9150-00-273-2389</b>
<b>LAW</b>	<b>- 1 qt.</b>	<b>- 9150-00-292-9689</b>
<b>Swabs</b>	<b>- 1,000</b>	<b>- 1005-00-288-3565</b>
<b>SD</b>	<b>- 1 gal.</b>	<b>- 6850-00-281-1985</b>
<b>RBC</b>	<b>- 6 oz.</b>	<b>- 6850-00-224-6657</b>
<b>LSA</b>	<b>- 4 oz.</b>	<b>- 9150-00-889-3522</b>

# BASIC ISSUE ITEMS

must be with your MACHINE GUN!

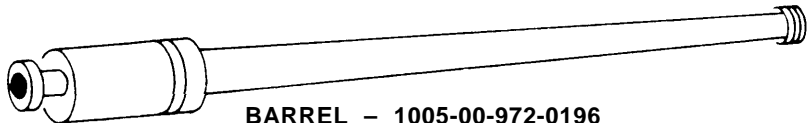

BARREL - 1005-00-972-0196

COMBINATION  
TOOL -  
4933-00-733-4759



WRENCH -  
5120-00-264-3793

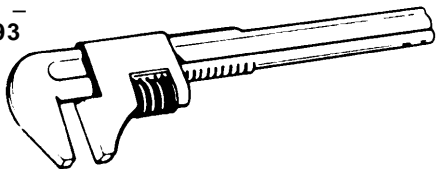

RUPTURED  
CARTRIDGE CASE EXTRACTOR -  
4933-00-652-9950



PUNCH -  
5120-00-242-5966

**MORE BASIC ISSUE ITEMS** must be with your VEHICLE!

**FLASH HIDER—  
1005-00-922-9777**



**M48A3, M60,  
M551 and XM706**

**FLASH SUPPRESSOR—  
1005-00-869-8817**

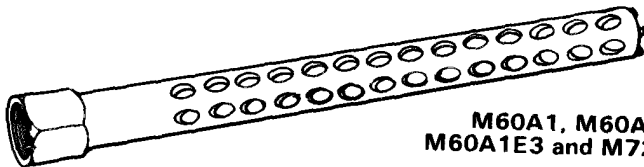

**M60A1, M60A2,  
M60A1E3 and M728**

**BARREL  
JACKET  
EXTENSION—  
1005-00-933-8070**

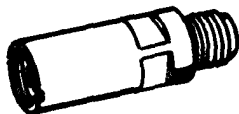

**M60A2 ONLY**

# HOW TO

install or remove your FLASH HIDER (the flash suppressor and the barrel jacket extension work the same way).

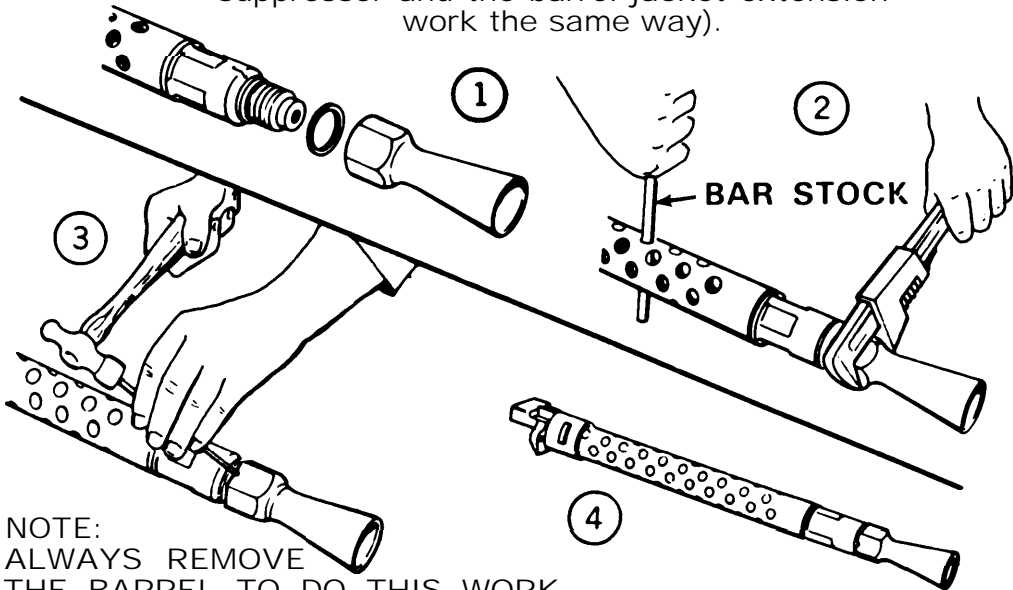

NOTE:  
ALWAYS REMOVE  
THE BARREL TO DO THIS WORK

**AMMO**

**7.62mm**

**WARNING**

**Use only certified ammo that  
is manufactured to U.S. spec's  
DODAC 1305, A131, A143**

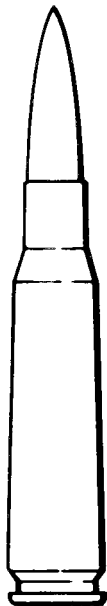

**M59 & M80  
BALL**

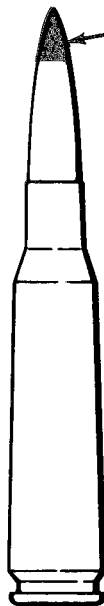

**M62  
TRACER**

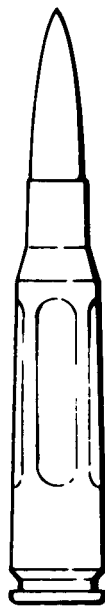

**M63  
DUMMY**

# BEFORE LOADING & FIRING

- Make sure the bore is dry and free of obstructions.
- Hand operate the gun using dummy cartridges — check feed components, safety and manual trigger.
- See that the electrical connections are good and that the firing solenoid works like it should.
- Install the gun in its mount (the operator's manual for your vehicle tells you how, along with boresighting and zeroing).

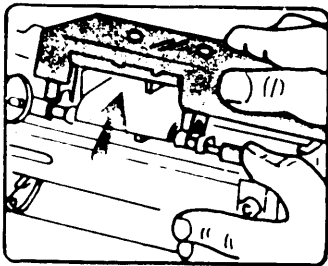

1. Push latch rod and raise cover.

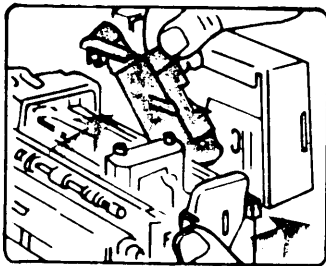

2. Raise feed tray and slide safety to "F".

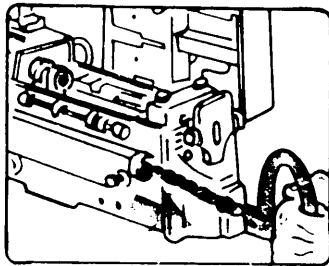

3. Pull handle to cock gun. Inspect chamber.

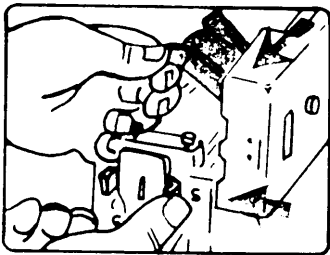

4. Slide safety to "S" and lower feed tray.

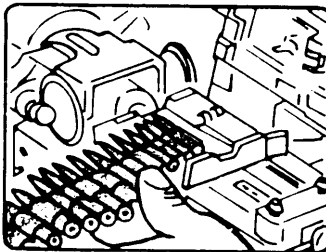

5. Place ammo in slot of feed tray, open side of links down.

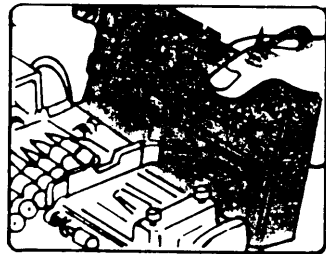

6. Close cover easy. Do not slam.

# FIRING

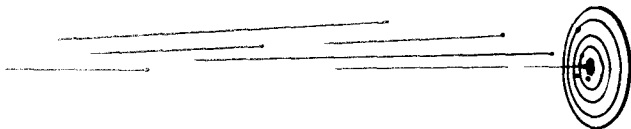

- **ELECTRICALLY**

TURN SWITCHES "ON"

SLIDE THE GUN SAFETY TO "F"

SIGHT IN THE TARGET AND  
PRESS THE FIRING BUTTON.

- **MANUALLY**

SLIDE THE GUN SAFETY TO "F"

SIGHT IN THE TARGET AND PRESS THE MANUAL TRIGGER  
ON THE MACHINE GUN.

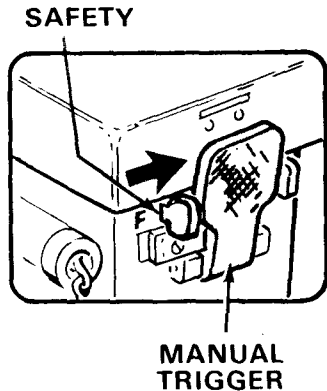



# UNLOADING

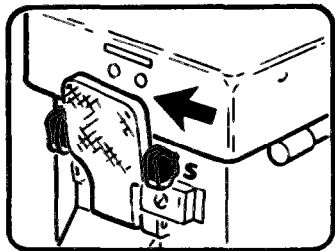

- "SAFE" YOUR MACHINE GUN
- TURN ELECTRICAL SWITCHES "OFF"
- OPEN THE COVER AND REMOVE THE BELTED AMMO

## WARNING

- CHECK THE CHAMBER, MAKE SURE IT'S EMPTY
- PUT SAFETY ON "F"
- HOLD CHARGING HANDLE, PRESS THE MANUAL TRIGGER, AND LET THE BARREL EXTENSION GO FORWARD SLOWLY!
- FINALLY, CLOSE THE COVER AND LEAVE SAFETY ON "F"

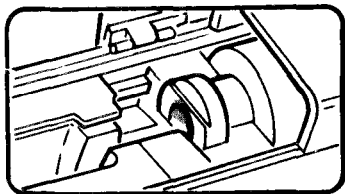

# IMMEDIATE **ACTION**

If your gun quits, here's what you'll do . . .

**WARNING** Stay on target, it might be a hangfire!

1. Charge the weapon and attempt to fire again (IF YOU'VE ALREADY FIRED 200 ROUNDS WITHIN 2 MINUTES YOU'D BETTER DO THIS IMMEDIATELY . . YOU COULD GET A COOK-OFF FROM YOUR HOT BARREL)!
2. Still no luck? **WARNING** If you've got a hot barrel, let it be for 15 minutes until it's cooled. If you open the cover now on a hot one, you could get an open-cover cook-off and big trouble!
3. Finally, open the cover, clear the gun.
4. Make sure the safety's on "F", and see if you can successfully hand function the gun one cycle.

# IMMEDIATE ACTION

5. if OK, reload like always, and attempt to fire.
6. still no-go? Clear the gun, and inspect it for the problem. The Troubleshooting Chart in this manual tells you what to do.

GOT A RUNAWAY GUN? ! ! ! (won't stop firing)

**WARNING** Stay aimed on target!

Jerk the charging handle to the rear, and HANG ON!

Then, open the cover and remove the belted ammo.

(The only fix YOU can try is to replace the barrel extension assembly).

# STUCK Cartridge ?

HERE'S HOW TO  
GET IT OUT!

## FIRST

Safe the gun

## THEN

(cover and feed tray up, of course)  
position the combination tool on the  
cartridge case lip as shown —  
press forward to lever it out.

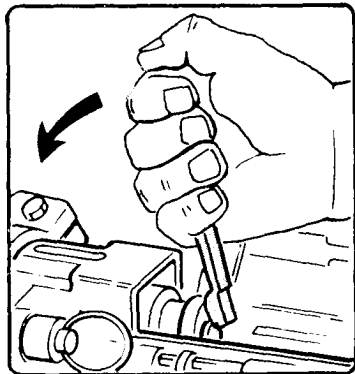

## **WARNING**

Inspect the bore to make sure the bullet  
isn't stuck in it! If so, remove the barrel and tap the  
bullet back out with the end of your cleaning rod.

# RUPTURED

Cartridge  
case ?

## HERE'S HOW TO SOLVE THAT ONE!

### FIRST

Replace the barrel.

### THEN

(as soon as combat conditions permit)  
Insert the \*ruptured cartridge case  
extractor through the broken case  
into chamber until the collet snaps  
over the front end of the case.

### Now

run your cleaning rod through the  
front of the barrel and drive out  
the extractor and case.

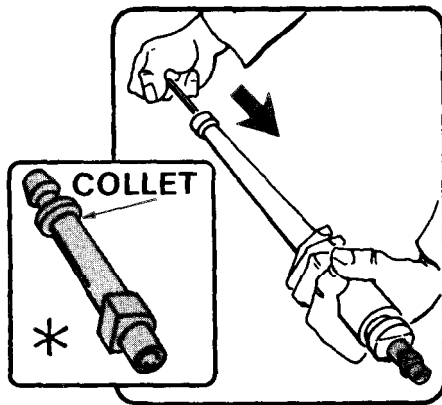

# TROUBLESHOOTING

IF YOUR GUN DOESN'T WORK, LOOK HERE – AND –  
IF THIS DOESN'T HELP, TAKE THE GUN TO ORGANIZATIONAL  
MAINTENANCE.

TROUBLE	CHECK THIS	FIX
<b>AMMO DOESN'T FEED</b>	<ol style="list-style-type: none"><li data-bbox="356 554 859 595">1. Cover unlatched.</li><li data-bbox="356 694 859 771">2. Ammo belt upside down.</li><li data-bbox="356 849 859 927">3. Barrel Extension forward when loaded.</li></ol>	<p data-bbox="895 554 1062 595">Latch it.</p> <p data-bbox="895 694 1332 771">Do it right, (open side of links down).</p> <p data-bbox="895 849 1252 890">Re-load correctly.</p>

TROUBLE	CHECK THIS	FIX
<p>more AMMO DOESN'T FEED</p>	<p>4. Bad link or ammo.</p> <p>5. Bad driving stud.</p>	<p>Take it out.</p> <p>Replace Barrel Extension Assembly.</p>
<p>AMMO DOESN'T CHAMBER</p>	<p>1. Obstruction in chamber.</p> <p>2. Bad Driving Springs.</p> <p>3. Bad Cartridge Rammer or Rammer Actuator Roller.</p>	<p>Clean it out.</p> <p>Replace them.</p> <p>Replace Barrel Extension Assembly.</p>

more TROUBLESHOOTING

TROUBLE	CHECK THIS	FIX
<b>GUN DOESN'T LOCK</b>	<ol style="list-style-type: none"><li data-bbox="338 274 808 321">1. <b>Bad Driving Springs.</b></li><li data-bbox="338 398 734 476">2. <b>Bad Breechblock Roller.</b></li><li data-bbox="338 533 838 621">3. <b>Bad Lever Actuator (breech closing) roller.</b></li><li data-bbox="338 647 853 771">4. <b>Feed Support Retainer out of position (in the cover).</b></li></ol>	<p data-bbox="890 274 1179 315"><b>Replace them.</b></p> <p data-bbox="890 398 1320 481"><b>Replace Breechblock Assembly.</b></p> <p data-bbox="890 533 1394 621"><b>Replace Barrel Extension Assembly.</b></p> <p data-bbox="890 647 1239 730"><b>Position Retainer Correctly.</b></p>
<b>GUN DOESN'T FIRE</b>	<ol style="list-style-type: none"><li data-bbox="338 813 615 854">1. <b>Bad ammo.</b></li><li data-bbox="338 885 690 927">2. <b>Bad Firing Pin.</b></li></ol>	<p data-bbox="890 813 1120 854"><b>Take it out.</b></p> <p data-bbox="890 885 1313 968"><b>Replace Breechblock Assembly.</b></p>



TROUBLE	CHECK THIS	FIX
more GUN DOESN'T FIRE	<b>3. Bad Firing Pin Extension.</b>	<b>Replace Barrel Extension Assembly.</b>
	<b>4. Bad Barrel Extension Assembly.</b>	<b>Replace it.</b>
GUN DOESN'T UNLOCK	<b>Bad Lever Actuator (breech closing) roller.</b>	<b>Replace Barrel Extension Assembly.</b>
SPENT CASE WON'T EXTRACT	<b>1. Short recoil.</b>	<b>Find the binding parts, then clean and lube as needed.</b>
	<b>2. Ruptured Cartridge Case.</b>	<b>Replace barrel. Take out ruptured case soon as you can.</b>

still more TROUBLESHOOTING

TROUBLE	CHECK THIS	FIX
<b>more SPENT CASE WON'T EXTRACT</b>	<b>3. Pitted Chamber.</b>  <b>4. Bad Cartridge Rammer, Extractor, or Extractor Spring.</b>	<b>Replace barrel.</b>  <b>Replace Barrel Extension Assembly.</b>
<b>RUNAWAY GUN</b>	<b>1. Bad Barrel Extension Assembly.</b>  <b>2. Bent Receiver Tabs or bad Sear adjustment</b>	<b>Replace Barrel Extension Assembly.</b>  <b>Take gun to Organi- zational Maintenance.</b>

<b>TROUBLE</b>	<b>CHECK THIS</b>	<b>FIX</b>
<p>If the <b>SPENT CASE WON'T EJECT</b>, or the <b>GUN WON'T COCK</b>, or it <b>FIRES ERRATICALLY</b>, the only fix is to replace the <b>Barrel Extension Assembly</b>. If this don't work, take your gun to <b>Organizational Maintenance</b>.</p>		

---

**Protect your Machine gun at all times. Cover with canvas, if possible. Moisture, dust and carbon makes it easy for your gun to malfunction.**

**The BIG FIX is to keep your Machine gun cleaned in other words, PREVENTIVE MAINTENANCE.**

# FIELD STRIP SAFETY ON "F" BARREL EXTENSION FORWARD

**WARNING** MAKE SURE THE CHAMBER IS EMPTY!

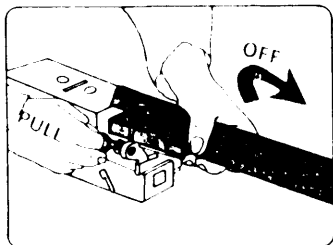

1. PULL DISCONNECTOR RINGS  
REMOVE BARREL JACKET.

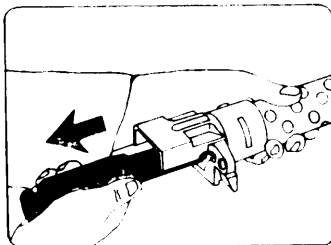

2. SLIDE BARREL OUT.

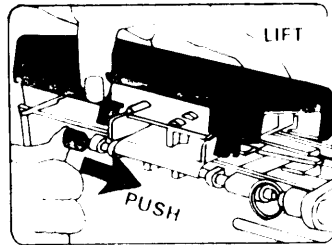

3.

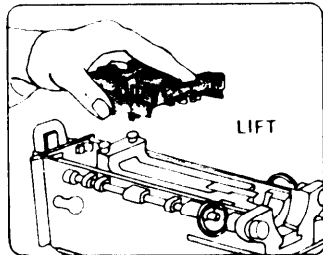

4.

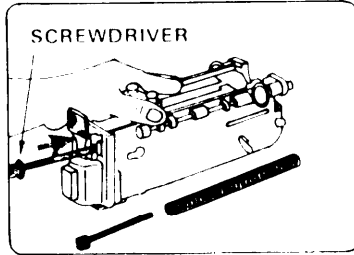

5. PUSH GUIDE RODS, TURN  
1/4 TURN, REMOVE.

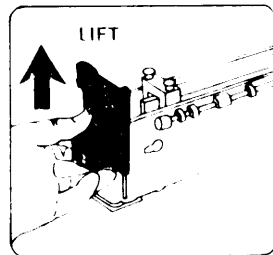

6.

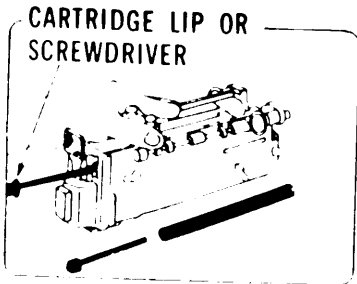

5. 1/4 TURN TO LOCK

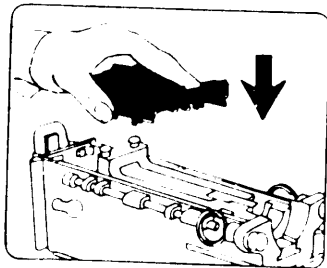

6.

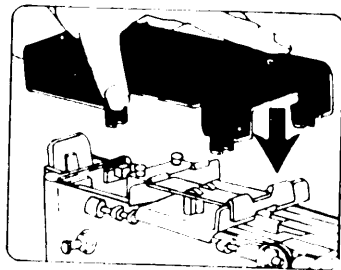

7.

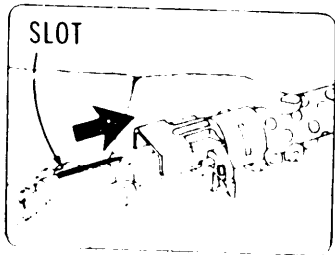

8. ALINE SLOT WITH  
BARREL LOCATOR.

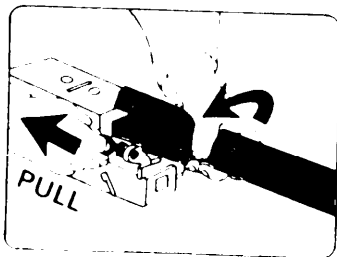

9.

OK, NOW IT'S  
ALL TOGETHER!

# CLEANING INSPECTION LUBRICATION

## HERE'S WHAT'S NEEDED:

After firing field strip your machine gun and clean all powder fouled surfaces with RBC.

Clean everything EXCEPT the Back Plate, Barrel Extension, Buffer and Charger Assemblies with SD. Wipe dry and lubricate.

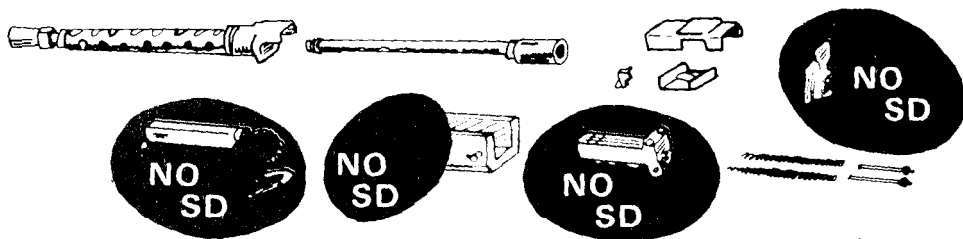

If your machine gun isn't used at all, it still needs complete cleaning and heavy lubing at least every 30 days. (Unusual conditions could shorten this interval.) Store weapon in horizontal position with safety "F" (fire position) and barrel extension forward.

**MORE**

## UNUSUAL CONDITIONS



**Extreme hot weather and humid salt-air conditions —**  
Your machine gun needs much more frequent servicing since this kind of climate quickly dissipates the lubricants.



**Extreme Cold Weather — Clean and lube with LAW only!**  
Hand operate the entire weapon often to keep the parts from freezing up. Keep the weapon covered and dry when not in use.



**Sandy and dusty conditions — Check often for fouled lubricants. Clean, relube often.**



**If your machine gun gets sopping wet inside, take it apart, dry it out and relubricate.**

SPECIAL LUBE INFO

LSA/PL Special works from -10°F and up,  
LAW is used only from 0°F and below.

**MORE** 

# CLEANING INSPECTION LUBRICATION

## BARREL BORE

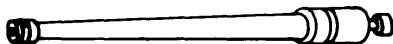

**C** Swab out with RBC, run the bore brush through it, then dry with clean patches.

✓ Check for: bulges, cracks, rust. Note: don't worry about that inside ring 8" in from the chamber end, it's a heat expansion gap.

**L** Finally, lube lightly. Note again: wipe out lube before firing.

## CHAMBER



**C** Insert the chamber brush, using RBC if necessary, turning to the left (it's a ratchet).

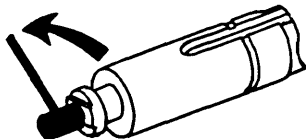



# CLEANING INSPECTION LUBRICATION

**BARREL JACKET** Clean, then



- ✓ everything for rust, corrosion.  
bearing block for staking, and barrel bearing for  
damaged threads.

L Finally, wipe on a light coat of lube.

## BACKPLATE & SOLENOID



**CAUTION** These parts must be kept dry – do not use SD or lube. Use only a clean rag and brush to remove dirt.

- ✓ Check spring action of trigger.
- ✓ Check trigger safety for proper functioning.
- ~~✗~~ DO NOT LUBE SOLENOID

# CLEANING INSPECTION LUBRICATION

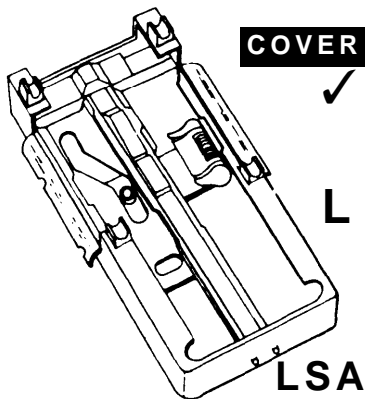

Clean, then

✓  
spring action of depressor and stripper.  
all pawls, under spring tension operate freely.  
that the whole thing locks properly to the receiver.

L  
Finally, a normal coat of lube, THEN:

Put a normal amount of LSA in these special places:  
recesses and grooves where the belt feed slide rides  
and where the feed cam rides. Operate these  
parts to spread it around.

## FEED TRAY

✓  
Clean, then  
cartridge stop secure.  
tray fits OK on the receiver.

L  
Finally, light coat of lube.

**NOTE:** leave  
top surface dry  
if gun is to be  
fired.

## **BARREL EXTENSION**

lube here and hand  
operate to spread around.

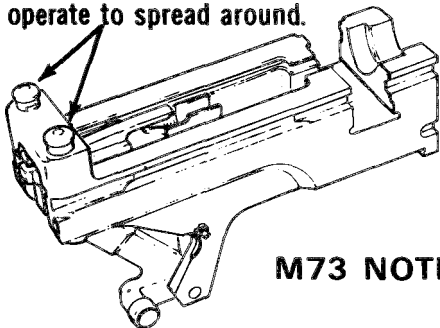

**NO  
SD**

Clean, then

- ✓ rammer assembly ✓ spring action in cartridge extractor and firing pin extension ✓ hammer sear housing tightly secured to the barrel extension
- ✓ hammer sear spring action ✓ lever assembly for freedom of action of rollers
- ✓ hammer functions properly.

**M73 NOTE DO NOT LUBE** Carrier Assembly grip surfaces if gun is to be fired.

**L** lube hammer sear spring through vent hole in hammer sear housing and actuate to spread the lube around.  
Lube the rest of the Barrel Extension and then . . . . .

**LSA** breechblock slideway, receiver rail slot cartridge rammer grooves and all roller riding surfaces. Hand operate these parts to spread it around.

# CLEANING INSPECTION LUBRICATION

## BREECHBLOCK

Clean, then

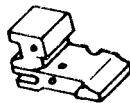

- ✓ roller moves freely.
- ✓ firing pin spring action.
- ✓ see that firing pin protrudes from breechblock.
- └ Finally, normal coat of lube.

## GUIDE RODS AND DRIVING SPRING

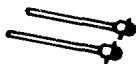

- Clean, then
- ✓ rods for straightness.
  - ✓ springs for kinks.
  - └ Lube normal

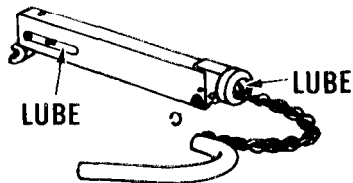

## CHARGER

- ✓ for loose parts.
- ✓ spring action by pulling on handle.
- └ Finally, lube as shown and operate to spread it around.

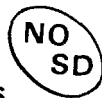

Clean, then

# CLEANING INSPECTION LUBRICATION

## RECEIVER

**C** Use the rectangular receiver brush, with RBC, to clean this item. Wipe dry. No SD on Buffer.

✓ spring action of the cover latch rods.

✓ spring action of buffer support levers

✓ functioning of rate control slide.

**L** Finally, wipe on a normal coat of lube.

**LSA**

LSA needed here:

Receiver rails, caroming groove areas for hammer cocking breech opening and breechblock roller.

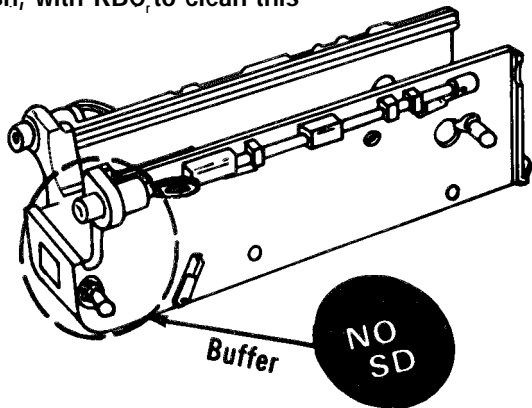

Buffer

NO  
SD

# HOW TO PUT IT BACK TOGETHER

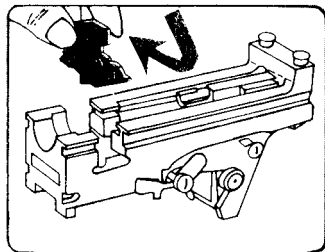
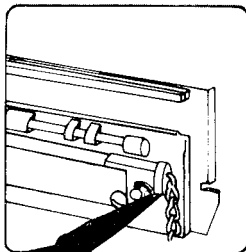
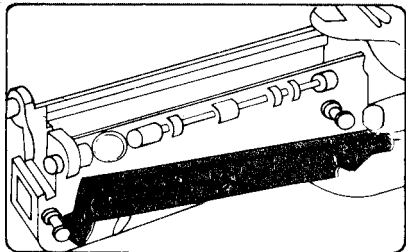

1.

2. NOTE: Right top edge of breechblock must be flush with right top edge of barrel extension.

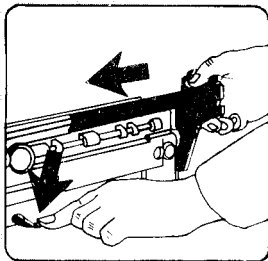

3.

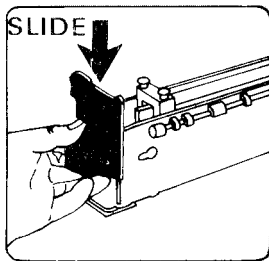

4.

**CAUTION:** Don't slam down — you could lower the receiver tabs, causing a runaway gun!

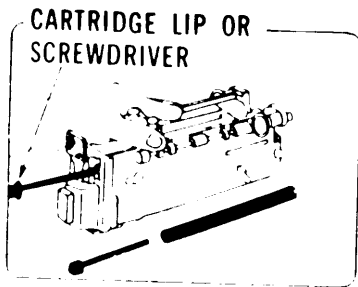

5. 1/4 TURN TO LOCK

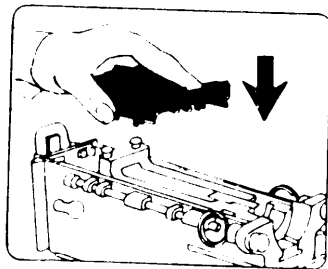

6.

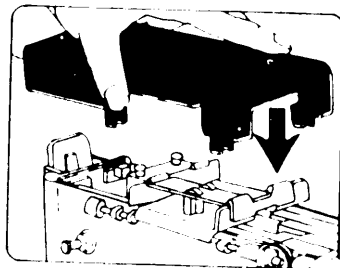

7.

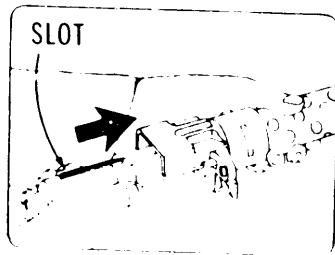

8. ALINE SLOT WITH  
BARREL LOCATOR.

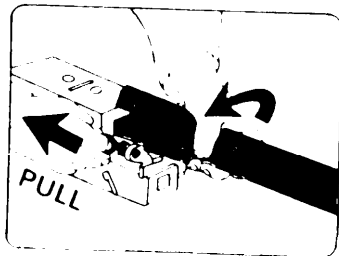

9.

OK, NOW IT'S  
ALL TOGETHER!

# CHECK IT OUT

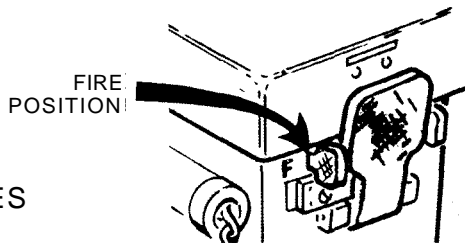

CHECK SAFETY SEVERAL TIMES  
AS FOLLOWS:

PLACE TRIGGER SAFETY AT "F" (FIRE POSITION). PULL CHARGER HANDLE TO REAR. KEEP HOLDING HANDLE. PUSH MANUAL TRIGGER, ALLOWING BARREL EXTENSION TO GO FORWARD SLOWLY. PULL CHARGER HANDLE, THEN PUT SAFETY ON "S" (SAFE POSITION). PUSH MANUAL TRIGGER. IF BARREL EXTENSION GOES FORWARD WHEN AT "S" OR DOES NOT GO FORWARD WHEN AT "F", NOTIFY ORGANIZATIONAL MAINTENANCE.



# CHANGING FROM RIGHT TO LEFT HAND FEED

(Changing back is the same process in reverse)

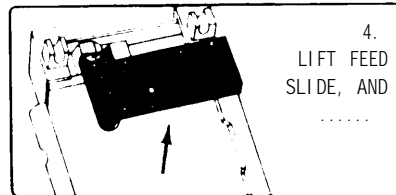
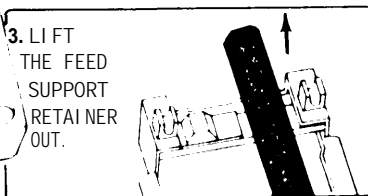
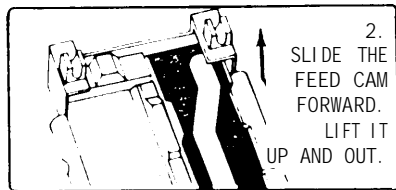
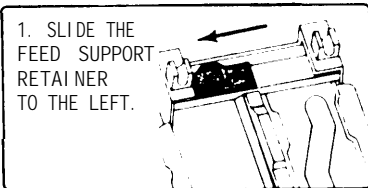
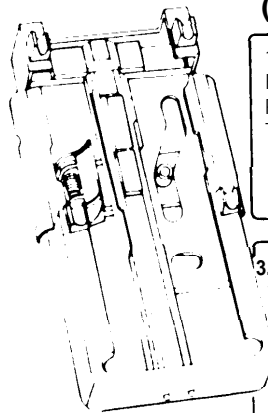

COVER  
set for RIGHT  
hand feed.

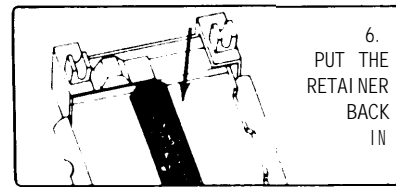

## more Changing from right to left hand feed

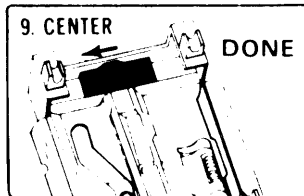
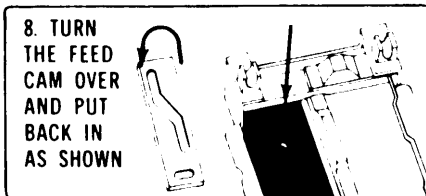
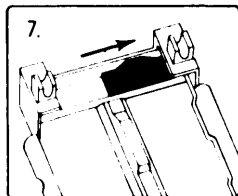

## CHANGING THE CHARGER

1. TAKE IT OFF THE RIGHT SIDE.
2. TAKE OUT THE STUD (M73E1, M219). PUT IN ON THE LEFT SIDE.
3. TURN THE FRONT STUD AROUND.

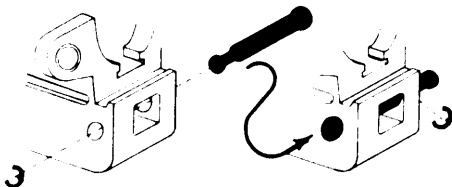

4. PUT THE CHARGER ON THE LEFT SIDE. DONE!

LEFT  
HAND FEED

## FEED TRAY

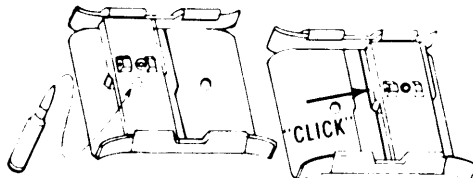

PUSH ON SPRING PLUNGER

DONE!

*This pub is for you!!!*

**Got Any Ideas?**

**Let Us Know!**

A line drawing of a hand holding a pen, pointing towards a callout box. The hand is wearing a sleeve with a button. The callout box is a trapezoidal shape with a pointer on the left side.

**DA FORM 2028  
(OR ANYTHING YOU HAVE HANDY)**

**COMMANDER  
U.S. ARMY ARMAMENT COMMAND  
ATTN: AMSAR-MAS  
ROCK ISLAND, ILLINOIS 61201**

**TM 9-1005-233-10**

**July, 1974**

**BY ORDER OF THE SECRETARY OF THE ARMY:**

**CREIGHTON W. ABRAMS**  
General, United States Army,  
Chief of Staff

**Official:**

**VERNE L. BOWERS**  
Major General, United States Army,  
The Adjutant General

**Distribution:**

To be distributed in accordance with  
DA Form 12-40 (qty Block No. 103).  
Operator and Crew Maintenance  
requirements for 7.62-MM Machine  
Gun, M73

**PIN: 026391-000**